

CAPACITY	SYMBOL/ SERIAL NO.	CIRCUIT DIAGRAM
AC 230V		
65W x 2		

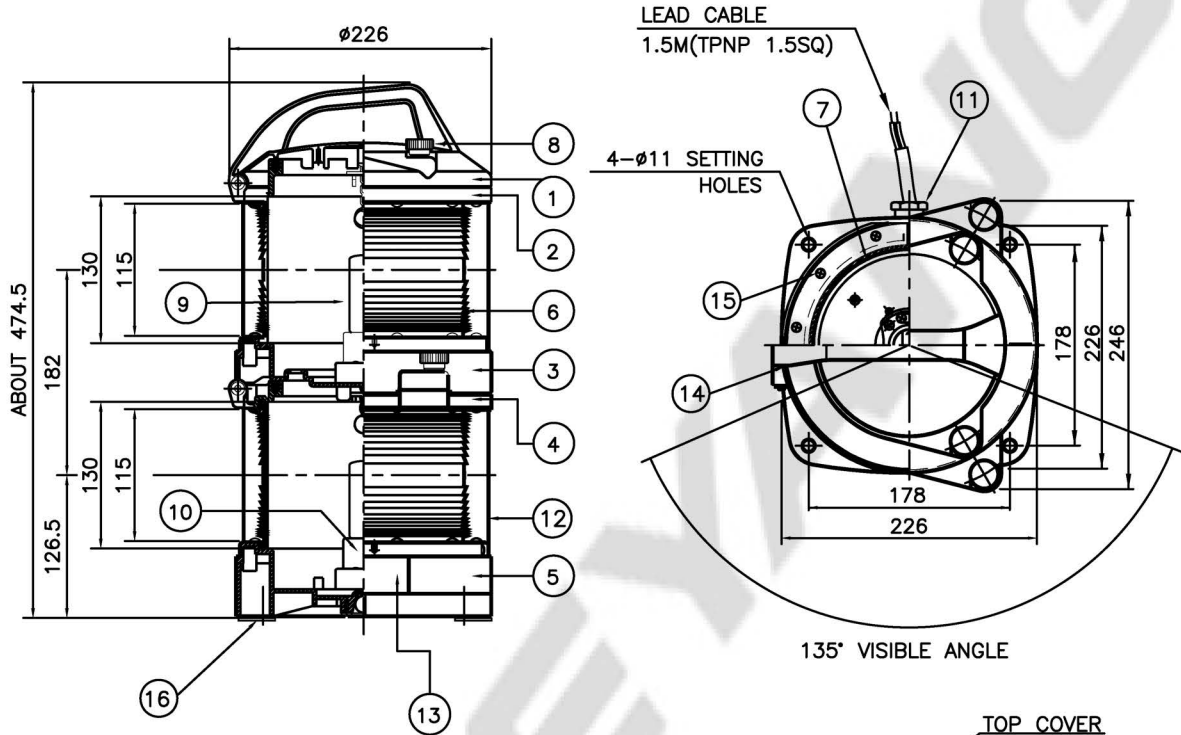

**NOTE**

1. APPLICATION RANGE : VESSEL OF 50M IN LENGTH AND ABOVE
2. MINIMUM VISIBILITY : 3 N.M

**\* CAUTION!!**

Do not install the navigation light upside down.  
Since breathing device is installed on the bottom of fixture.

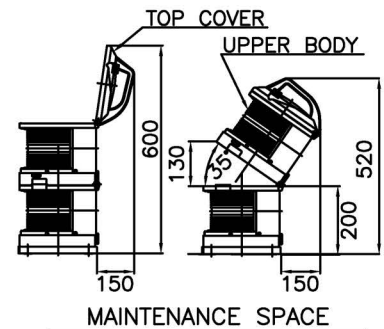

16	ANTI-VIBRATION PACKING	C.R.	4	5.0mm	8	CLAMP BOLT	BRASS	4	
15	T/H TAPPING SCREW	STAINLESS STEEL 304	48	M4	7	GASKET	SILICONE RUBBER	2	
14	HINGE	POLYCAR-BONATE	2		6	LENS	POLYCAR-BONATE	2	DARK CLEAR
13	NAME PLATE	STAINLESS STEEL 316L	1		5	LOWER BODY	POLYCAR-BONATE	1	
12	SHIELD PLATE	STAINLESS STEEL 304	2		4	LOWER TOPPER	POLYCAR-BONATE	1	
11	CABLE GLAND(#20)	NYLON	2	ø12~ø15	3	UPPER BODY	POLYCAR-BONATE	1	
10	LAMP HOLDER	PPS	2	P28s	2	UPPER TOPPER	POLYCAR-BONATE	1	
9	NAVIGATION LIGHT LAMP	-	2	P28s	1	TOP COVER	POLYCAR-BONATE	1	
NO	NAME OF PARTS	MATERIAL	Q'TY	REMARKS	NO	NAME OF PARTS	MATERIAL	Q'TY	REMARKS

APPROVED	B. K. KIM	UNIT	MM	TITLE;  STERN LIGHT FOR MARINE USE			
CHECKED		SCALE	N/S				
DRAWING	B. I. KIM	COLOR	MAT BLACK				
DATE	2015.12.04	IP	56				
				MODEL NO.	A2P-DS6523Hh-1.5M-MED	WEIGHT	5.76 Kg
				DWG NO.	L31240076	SHEET NO.	22